

Radon



Bureau of Environmental Health
and Radiation Protection

Ohio Department of Health
35 E. Chestnut Street
Columbus, OH 43215

614-728-0272

www.odh.ohio.gov



Department
of Health

Table of Contents

Overview	3
What is Radon?	3
What is the Risk of Living With Radon?	3
How Does Radon Get into my Home?	3
Is Radon Found in Homes in Ohio?	3
Selling Your Home & Radon	4
Seller Checklist	5
Buying a Home & Radon	6
Buyer Checklist	7
Selecting an Ohio Licensed Radon Contractor	8
Testing	8
Mitigation	8
Proper Radon Testing	9
Testing Checklist	9
Closed Home Conditions	9
Proper Radon Test Kit Placement	10
Understanding Radon Test Results	11
How to Lower Elevated Levels of Radon	12
Post-mitigation	12
Radon-resistant New Construction	14
Radon-resistant New Construction Components	14
Why Buy a Radon-Resistant Home?	15
Resources	16

Overview

What is radon?

Radon is a colorless, odorless radioactive gas that comes from the natural breakdown (decay) of uranium in soil and rocks.

What is the risk of living with radon?

Exposure to elevated levels of radon over the course of your lifetime increases your risk of developing lung cancer. The surgeon general has warned that [radon is the second leading cause of lung cancer in the United States](#). Radon is also the leading cause of lung cancer among non-smokers. Smoking greatly increases your risk of getting lung cancer from radon exposure.

How does radon get into my home?

Radon moves into your home by migrating through cracks or openings in the foundation. Any home can have elevated levels of radon, whether or not you have a basement and regardless of if your home is old or new.

Is radon found in homes in Ohio?

Elevated levels of indoor radon have been found in homes in every county of Ohio. Every year approximately [50%](#) of all homes tested in Ohio have elevated levels of radon.

[Your chance of being affected by radon largely depends on:](#)

- [Your home's radon level – to find this out, it must be tested!](#)
- [The amount of time you spend in your home](#)
- [Whether you are a smoker or have ever smoked](#)

Selling Your Home & Radon

The Ohio Department of Health (ODH) recommends performing a radon test before selling your home. If your home has elevated levels of indoor radon, you should have a radon mitigation system installed to lower the radon levels. Use the following guide to determine if you need to test your house for radon before you sell your home.

Have you tested your current home for radon?

Yes, I have tested my home for radon

Locate the paperwork indicating your test results. You may need to conduct another test if you did not test according to Ohio's testing protocols.

Other reasons to perform another test:

- Test was not performed by a licensed tester
- You cannot provide the buyer with a copy of the test report
- It has been two years or more since you tested
- Since you last tested you have:
 - installed energy-efficient windows and/or doors
 - replaced the roof
 - added insulation
 - completed major renovations

If you do need to perform a new radon test, ODH recommends you use an Ohio licensed radon tester to perform the test.

No, I have not tested my home for radon

ODH recommends hiring an Ohio licensed radon tester to perform a radon test. Home buyers are advised not to accept test results performed by the current homeowner unless they can prove they tested according to Ohio testing protocols. If you want to perform the test yourself, make sure you follow the proper testing procedures listed on pages 10-11 of this guide and refer to ODH rules.

Seller Checklist

Has your home had a radon test? Yes No

If **No**, have your home tested, then complete this form.

If **Yes**, answer the following questions:

1. **When was the radon test performed?** _____
(If two or more years ago, have your home tested again—even if the home already has a radon mitigation system)

2. **Who performed the test?**
 You Ohio licensed radon tester
(If homeowner, contact an Ohio licensed tester and have another test performed)

3. **Do you have a copy of the radon test report?** Yes No
(If NO, contact the Ohio licensed tester who performed the test or the lab that analyzed the test kit to obtain a copy)

4. **Have you replaced or installed any of the following since the last radon test?**
 - a. **Windows** Yes No
 - b. **Insulation** Yes No
 - c. **Roof** Yes No
 - d. **Exterior doors** Yes No
 - e. **Furnace or air conditioner** Yes No(If YES to any of the above, have your home tested again)

5. **What were the test results?** _____ pCi/L
(If greater than 4 picoCuries per liter of air, this is elevated and needs to be reported to your realtor and any potential home-buyers. Consider installing a radon mitigation system)

Buying a Home & Radon

ODH recommends that you have a radon test performed before you purchase a home. Ask the homeowner if they have had the home tested. If the homeowner has not tested the home, hire an Ohio licensed radon tester to perform a radon test. If the homeowner has tested their home, they should provide you with the test results. It is important to verify if the radon test was done properly and according to Ohio rules.

ODH recommends that you perform another test for any of the following reasons:

- it has been **two or more years** since the last test
- the test was **not** performed on the lowest level of the home suitable for occupancy
- the testing time was less than **48 hours**
- **improvements have been made** to the home since the last test was performed

Buyer Checklist

- **Has the home had a radon test?** Yes No
If **No**, have the home tested, then complete this form.
If **Yes**, answer the following questions:
 1. **When was the test performed?** _____
(If two or more years ago, have the home tested again – even if the home already has a radon mitigation system)
 2. **Who performed the test?**
 Homeowner Ohio licensed radon tester
(If homeowner, contact an Ohio licensed tester and have another test performed)
 3. **Can the homeowner provide the radon test report?**
(If **NO**, have the home tested again) Yes No
 4. **Has the homeowner replaced or installed any of the following since the last radon test:**
 - a. **Windows** Yes No
 - b. **Insulation** Yes No
 - c. **Roof** Yes No
 - d. **Exterior doors** Yes No
 - e. **Furnace or air conditioner** Yes No(If **YES** to any of the above, have the home tested again)
 5. **What were the test results?** _____ pCi/L
 6. **If the test results were 4pCi/L or higher, was a radon mitigation system installed?** Yes No
(If **No**, have the home tested again. Radon levels are likely high)
(If **Yes**, ask to see test results from after installation)

Selecting an Ohio Licensed Radon Contractor

Testing

The Indoor Radon Program at ODH recommends that all homes in Ohio are tested for radon. Ohio licensed radon testers perform testing in strict compliance with State of Ohio radon testing protocols and will provide their clients with accurate and impartial test results. If you choose to perform the radon test yourself, you need to test according to Ohio testing protocols and keep detailed documentation of this process.

Mitigation

Any mitigation measures taken or systems installed in your home must conform to ODH rules. [The mitigation contractor must be licensed](#) BY ODH. You can find a list of all Ohio licensed radon contractors on the ODH Indoor Radon Program web site.

www.odh.ohio.gov

You should get more than one estimate, ask for references, and check with a reliable consumer group or agency before selecting a mitigation contractor.



Proper Radon Testing

Following the proper radon testing guidelines is essential for determining the average radon levels in a home. Below are the guidelines according to Ohio radon testing protocols. These steps should be followed regardless who is performing the radon test.

Testing Checklist

- Observe **closed home conditions** (see below)
- Place the test device in the **lowest level that could be occupied**, regardless if it is currently used by the homeowner.
- The radon test must be conducted for at least **48 hours**.
- The home's HVAC should be operating.
- Fans of any kind **should not** be used during the test.
- If a home has a radon mitigation system, **do not** turn it off during the radon test.

Closed Home Conditions

Observing closed home conditions means keeping **all** windows on **all** levels of the home closed and keeping all exterior doors closed except for normal entrances and exits **12 hours** prior to the start of the radon test and for the duration of the test. The heating and cooling system should be operated normally. Not observing closed home conditions will cause the test results to be unreliable.

Do not interfere with the testing device. Interference will invalidate the test results and another test will need to be performed.

Proper Radon Test Kit Placement

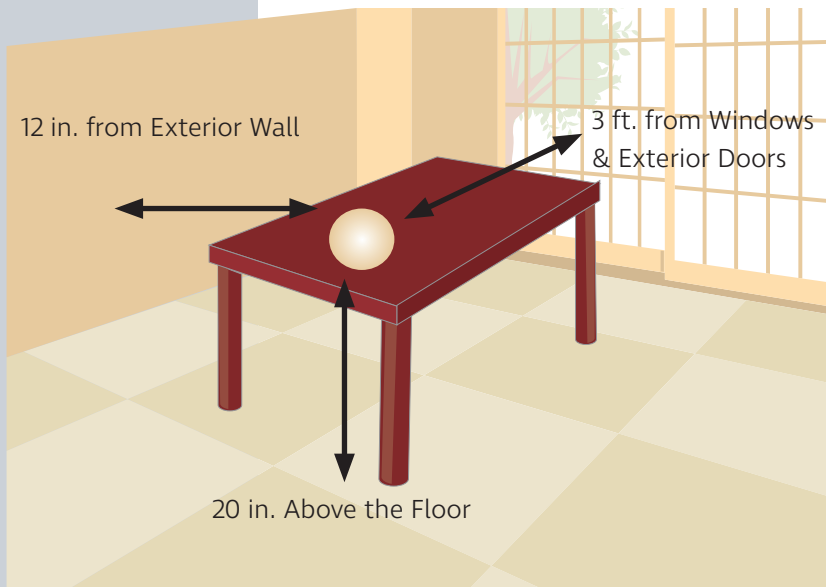

Proper placement of the test kit includes placing the kit:

- At least 20 inches above the floor
- At least 12 inches from an exterior wall
- At least 3 feet from windows/exterior doors
- At least 4 inches from other objects
- At least 10 feet from a sump pit
- At least 4 feet from the furnace or heat source
- Out of the direct flow of air from ventilation ducts
- Out of direct sunlight
- In a frequently occupied room, but not placed in areas of high humidity such as a kitchen, bathroom or laundry room

Understanding Radon Test Results

Radon is measured in [picocuries of radon per liter of air \(pCi/L\)](#). Radon test results will indicate the AVERAGE radon level for the testing period (must be at least 48 hours of continuous data). Since radon levels fluctuate on an hourly, daily and seasonal basis, the results will always be an average level for the testing period.

The [U.S. Environmental protection agency \(EPA\)](#) has set an [action level of 4pCi/L](#). This means that if the AVERAGE radon level is 4pCi/L or higher, you should act to lower the radon levels in the home.

How to Lower Elevated Levels of Radon

A radon mitigation system should be installed to lower the radon levels to below 4pCi/L. PVC pipes and a special type of fan are the basic components of a radon mitigation system.

The most common radon mitigation system installed is a “sub-slab depressurization” system. This system pulls the radon out from underneath the foundation and vents it to the outside. An Ohio licensed radon contractor will be able to determine the right system for your home.

The contractor should also seal all cracks and openings in the foundation floor and walls.

ODH does not recommend the use of sealing alone to reduce elevated levels of radon.

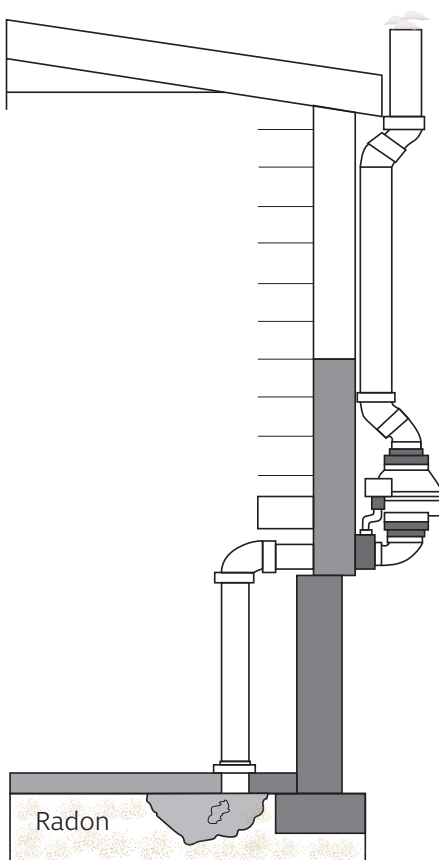

Post-mitigation

The radon contractor must perform a post-mitigation radon test. This is done to verify that the radon system has reduced the average radon level to below 4pCi/L. This test should be done within 30 days of the system installation, but no sooner than 24 hours after the system is in operation.

After a radon mitigation system has been installed, homes should still be [tested for radon at least every two years](#), to ensure that the systems are working properly and that radon levels remain low.

Make sure the contractor completely explains the radon reduction system to you, demonstrates how it operates, and explains how to maintain it.

If you decided to make major structural changes to your home after you have had a radon reduction system installed (such as converting an unfinished basement area into living space), ask your radon contractor whether these changes could void any warranties. After you remodel, retest in the lowest lived-in level to make sure the construction did not reduce the effectiveness of the system.

Radon-resistant New Construction

Radon-Resistant New Construction Components

- **Gravel:** A layer of clean, coarse gravel below the foundation or an alternative, such as a perforated pipe or a collection mat is installed.
- **Plastic Sheetting or Vapor Barrier:** Heavy-duty plastic sheeting or a vapor barrier is used over the gravel to inhibit radon and other soil gases from entering the house.
- **A Vent Pipe:** A vent pipe is installed vertically from the gravel layer through the house's conditioned space and roof. This safely vents radon and other soil gases outside the house.
- **Sealing and Caulking:** All openings, cracks, and crevices in the concrete foundation and walls are sealed with polyurethane caulk to prevent radon and other soil gases from entering the home.
- **Junction Box:** An electrical junction box (outlet) is installed in the attic for use with a vent fan. If after testing for radon an elevated level of radon is detected a fan can easily be installed.

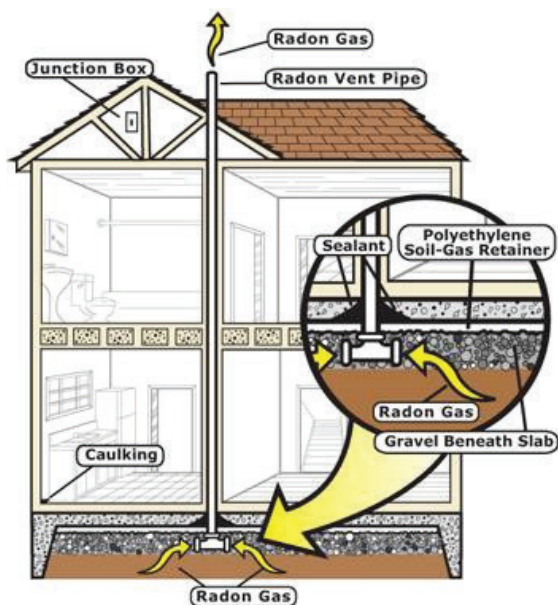

Why Buy a Radon-resistant Home?

- **The Techniques Work**

Simple and inexpensive techniques reduce radon levels on average by 50%. The techniques may also lower levels of other soil gases and decrease moisture problems.

- **It is Cost Effective**

Building in the features is much cheaper than fixing a radon problem later. Installing a radon mitigation system in a home after it is built can cost \$2,000 or more.

- **It Saves Money**

The techniques described here also make your home more energy efficient and could provide you savings in your energy costs.

Resources

Additional information about radon can be found on the following websites:

ODH Indoor Radon Program

www.odh.ohio.gov

Ohio Radon Information System

<http://www.eng.utoledo.edu/aprg/radon/>

U.S. Environmental Protection Agency

www.epa.gov/radon

If you have questions about information contained in this guide you may contact the Indoor Radon Program at ODH at indoor.radon@odh.ohio.gov or by calling 1-800-523-4439.

The purpose of this guide is to provide information about radon and radon testing as a part of real estate transactions. The information in this guide is specific to Ohio Revised Code, Chapter 3723 and Ohio Administrative Code, Chapter 3701-69 and should not be used as a reference in any other state.



Department
of Health